

Română

Agricultural telehandlers

MLT NewAg

MLT 940-140 V+

MACHINEBOOK



Capacities		Metric
Capacitate maximă	Q	4000 kg
Înălțime max. de ridicare	h3	9 m
Rază de acțiune maximă		6.55 m
Rată de acțiune la înălțime maximă		2.40 m
Forță de susținere verticală cu cupă		5402 daN
Greutate și dimensiuni		
Unladen weight (with forks)		8361 kg
Gardă la sol utilaj	m4	0.42 m
Ampatament	y	2.81 m
Lungime globală la cărucior (cu cuplaj)	l11	5.12 m
Lungime globală la cărucior (fără cuplaj)	l3	4.94 m
Consolă față		1.36 m
Lățime globală	b1	2.39 m
Lățime globală cabină	b4	0.95 m
Înălțime globală	h17	2.38 m
Unghi înclinare jos	a5	133 °
Unghi înclinare sus	a4	14 °
Rază de bracăj exterioară (peste anvelope)	Wa1	3.93 m
Standard tires		Alliance - A580 - 460/70 R24 159A8
Drive wheels (front / rear)		2 / 2
Steering wheels (front / rear)		2 / 2
Performances		
Lifting		6.50 s
Lowering		7.20 s
Extensie telescop		11 s
Retragere		8.10 s
Excavație		3.20 s
Descărcare		2.90 s
Engine		
Marcă		Deutz
Engine norm		Stage V / Tier 4 Final
Tip		TCD 3.6 L4
Number of cylinders - Capacity of cylinders		4 - 3621 cm ³
I.C. Engine power rating / Power		136 Hp / 100 kW
Max. torque / Engine rotation		500 Nm @1600 rpm
Forță de tracțiune pe orizontală		6200 daN
Ventilator reversibil		Standard
Engine cooling system		4 radiators (water + intercooler + hydraulic oil + transmission oil)
HVO validated (according to EN 15940 standard)		Da
Transmission		
Transmission type		M-Vario Plus
Viteză maximă de deplasare (poate varia în funcție de reglementările în vigoare)		40 km/h
Differential lock		Limited slip differential on front axle
Frână de parcare		Automatic negative parking brake
Service brake		Oil-immersed multi-discs braking on front & rear axles
Hydraulics		
Tip pompă		Variable displacement pump
Debit hidraulic - Presiune hidraulică		170 l/min - 270 bar
Distribuitor cu partajare debit		Standard
Tank capacities		
Capacitate rezervor de carburant		120 l
Diesel Exhaust fluid (AdBlue® type)		10 l
Noise and vibration		
Zgomot la poziția de conducere (LpA) testat conform noimei NF EN 12053		72 dB
Zgomot în mediu (LwA)		105 dB
Vibrație la brațe/mâini		< 2.50 m/s ²
Miscellaneous		
Tractor homologation		Tractor homologation
Safety cab homologation		ROPS - FOPS level 2 cab
Controale		JSM

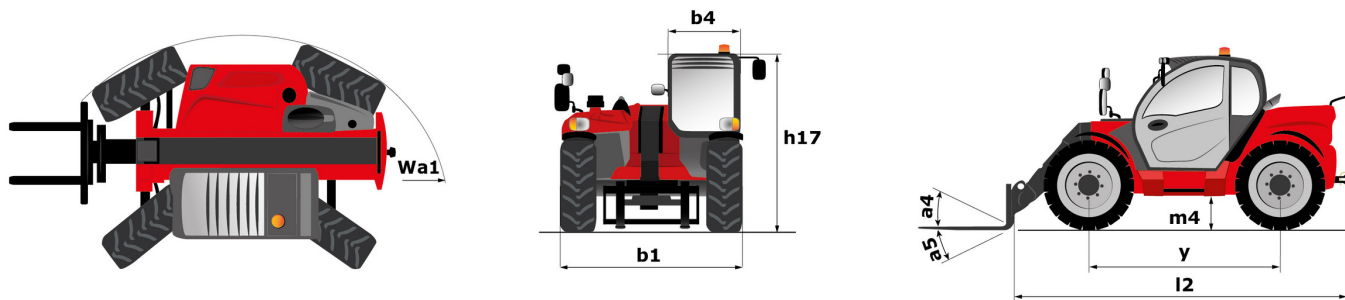

MLT 940-140 V+ - DIAGRAMĂ DE ÎNCĂRCARE

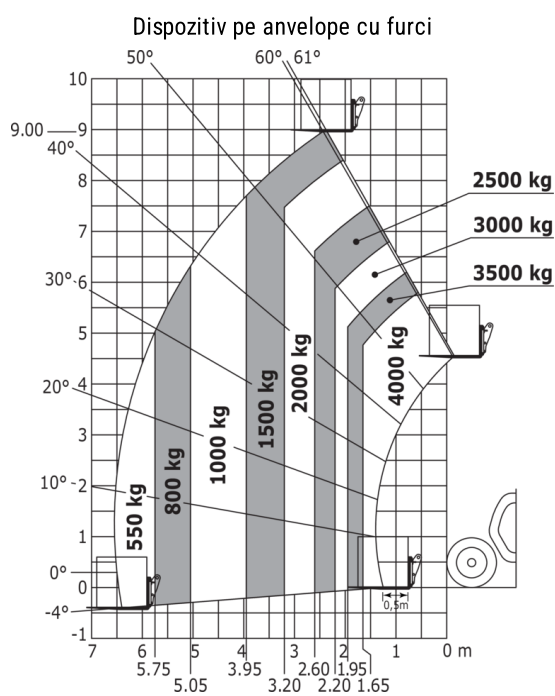

BUCKETS

Agricultural Bucket

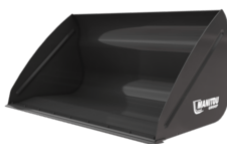

Agricultural Bucket - CBA 2000 / 2450

Distance to center of gravity	Capacity	Heaped capacity	Struck capacity	Greutate	Înălțime globală
485 mm	2010 kg	2010 l	1484 l	557 kg	1150 mm
Lungime totală	Lățime	Reference number	Reference number with bolted wearplate (WP)		
1204 mm	2450 mm	570551	570552		

Mandatory machine equipment: ✕

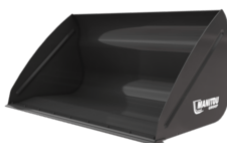

Agricultural Bucket - CBA 2500L / 2450

Distance to center of gravity	Capacity	Heaped capacity	Struck capacity	Greutate	Înălțime globală
537 mm	2526 kg	2526 l	1916 l	675 kg	1250 mm
Lungime totală	Lățime	Reference number	Reference number with bolted wearplate (WP)		
1497 mm	2450 mm	570553	570554		

Mandatory machine equipment: ✕

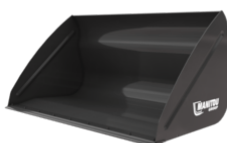

Agricultural Bucket - CBA 3000 / 2500

Distance to center of gravity	Capacity	Heaped capacity	Struck capacity	Greutate	Înălțime globală
583 mm	3023 kg	3023 l	2342 l	753 kg	1314 mm
Lungime totală	Lățime	Reference number	Reference number with bolted wearplate (WP)		
1733 mm	2500 mm	570555	500701		

Mandatory machine equipment: ✕

BUCKETS

Agricultural Multifunction Grab Bucket - FO



Agricultural Multifunction Grab Bucket - FO - BG 2450 / 1400 FO

Distance to center of gravity	Capacity	Heaped capacity	Struck capacity	Greutate	Lungime totală
407 mm	1426 kg	1426 l	868 l	803 kg	1256 mm
Lățime	Closed grab height	Opened grab height	Reference number		
2450 mm	1033 mm	1675 mm	52647333		

Mandatory machine equipment: 



Agricultural Multifunction Grab Bucket - FO - BG 2450 / 1700 FO

Capacity	Heaped capacity	Struck capacity	Greutate	Lungime totală	Lățime
1695 kg	1695 l	1150 l	870 kg	1367 mm	2450 mm
Closed grab height	Opened grab height	Reference number			
1124 mm	1886 mm	52549810			

Mandatory machine equipment: 

BUCKETS

Agricultural Multifunction Grab Bucket - WE



Agricultural Multifunction Grab Bucket - WE - BG 2450 / 1400 WE

Distance to center of gravity	Capacity	Heaped capacity	Struck capacity	Greutate	Lungime totală
418 mm	1426 kg	1426 l	868 l	813 kg	1280 mm
Lățime	Closed grab height	Opened grab height	Reference number		
2450 mm	1033 mm	1776 mm	52647332		

Mandatory machine equipment: 



Agricultural Multifunction Grab Bucket - WE - BG 2450 / 1700 WE

Distance to center of gravity	Capacity	Heaped capacity	Struck capacity	Greutate	Lungime totală
1021 mm	1695 kg	1695 l	1150 l	895 kg	1377 mm
Lățime	Closed grab height	Opened grab height	Reference number		
2450 mm	1124 mm	1979 mm	52549720		

Mandatory machine equipment: 

BUCKETS

Bucket 4 in 1



Bucket 4 in 1 - CB4x1 900L / 2450

Distance to center of gravity	Capacity	Heaped capacity	Struck capacity	Greutate	Înălțime globală
380 mm	1888 kg	899 l	672 l	714 kg	890 mm
Lungime totală	Lățime	Reference number	Reference number TSDL		
1110 mm	2450 mm	751465	52000368		

Mandatory machine equipment: 

BUCKETS

Environment Grab Bucket



Environment Grab Bucket - CBG 2450 / 1600 EN

Capacity	Heaped capacity	Struck capacity	Greutate	Lungime totală	Lățime
1568 kg	1568 l	1262 l	926 kg	1259 mm	2450 mm
Opened grab height	Reference number				
1868 mm	52000563				

Mandatory machine equipment: 



Environment Grab Bucket - CBG 2450 / 1600 EN WB

Distance to center of gravity	Capacity	Heaped capacity	Struck capacity	Greutate	Lungime totală
609 mm	1568 kg	1568 l	1262 l	947 kg	1259 mm
Lățime	Opened grab height	Reference number			
2450 mm	1868 mm	52000766			

Mandatory machine equipment: 

BUCKETS

General Purpose Bucket

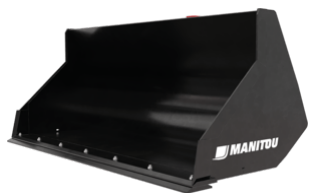

General Purpose Bucket - CBR 1000 / 2450

Capacity	Heaped capacity	Struck capacity	Greutate	Înălțime globală	Lungime totală
2079 kg	990 l	804 l	381 kg	775 mm	815 mm
Lățime	Reference number	Reference number with bolted wearplate (WP)	Reference number TSDL		
2450 mm	654716	52000370	52000366		

Mandatory machine equipment: 

BUCKETS

General Purpose Bucket Essential

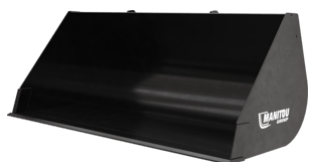

General Purpose Bucket Essential - BGP 2450 / 1000 Essential

Distance to center of gravity	Capacity	Heaped capacity	Struck capacity	Greutate	Înălțime globală
434 mm	2089 kg	995 l	766 l	397 kg	786 mm
Lungime totală	Lățime	Depth	Reference number		
925 mm	2450 mm	817 mm	52658055		

Mandatory machine equipment: 

BUCKETS

Shear buckets



Shear buckets - SHB 2400 / 1800

Distance to center of gravity	Capacity	Heaped capacity	Greutate	Înălțime globală	Lungime totală
522 mm	1800 kg	1800 l	1080 kg	1010 mm	1295 mm
Lățime	Opened grab height	Depth	Reference number		
2454 mm	1475 mm	850 mm	52000387		

Mandatory machine equipment: 



BUCKETS

Silage Facing Bucket



Silage Facing Bucket - CRS 2550 / 2000

Capacity	Heaped capacity	Greutate	Lățime	Reference number
2000 kg	2000 l	955 kg	2550 mm	52612540

Mandatory machine equipment:  + 

BUCKETS

Sugar Beet Bucket

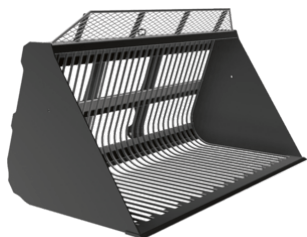

Sugar Beet Bucket - BSB 2450 / 2500

Distance to center of gravity	Capacity	Heaped capacity	Greutate	Înălțime globală	Lungime totală
502 mm	1390 kg	2500 l	520 kg	1380 mm	1375 mm
Lățime	Depth	Reference number			
2450 mm	1280 mm	757953			

Mandatory machine equipment: ✗

CLAMPS

Bale clamp classic



Bale clamp classic - CLBR 2x3

Capacity	Greutate	Înălțime globală	Lungime totală	Forks length	Lățime
1200 kg	235 kg	1382 mm	1082 mm	335 mm	1090 mm
Arm length	Reference number				
700 mm	52001013				

Mandatory machine equipment: 



Bale clamp classic - PBG 2x4

Capacity	Greutate	Înălțime globală	Lungime totală	Forks length	Lățime
1800 kg	235 kg	1381 mm	1031 mm	335 mm	1090 mm
Arm length	Reference number				
600 mm	757612				

Mandatory machine equipment:

CLAMPS

Bale clamp high intensive



Bale clamp high intensive - CLBR 2x6

Capacity	Greutate	Înălțime globală	Lungime totală	Forks length	Lățime
2000 kg	434 kg	2256 mm	1276 mm	335 mm	1002 mm
Arm length	Reference number				
700 mm	757666				

Mandatory machine equipment:

CLAMPS

Bale Clamp Super Compact



Bale Clamp Super Compact - PBG 2x2

Capacity	Greutate	Înălțime globală	Lungime totală	Forks length	Lățime
800 kg	156 kg	869 mm	922 mm	335 mm	1090 mm
Arm length	Reference number				
500 mm	757639				

Mandatory machine equipment:

CLAMPS

Mixed Bale Clamp



Mixed Bale Clamp - MBC 2x3

Capacity	Greutate	Înălțime globală	Lungime totală	Fork spread	Lățime
800 kg	290 kg	1084 mm	1454 mm	375 mm	1196 mm
Reference number					
790506					

Mandatory machine equipment:

CLAMPS

Square Bale Clamp



Square Bale Clamp - CLBS 2x7 / 2100

Capacity	Greutate	Înălțime globală	Lungime totală	Forks length	Lățime
2100 kg	760 kg	3010 mm	1590 mm	1000 mm	1800 mm

Reference number

52000015

Mandatory machine equipment: 

CLAMPS

Square wrapped bale clamp



Square wrapped bale clamp - CLBSW 2000 / 1000

Capacity	Greutate	Înălțime globală	Lungime totală	Lățime	Arm length
1000 kg	483 kg	679 mm	1849 mm	1525 mm	1000 mm

Reference number

52000812

Mandatory machine equipment: 

CLAMPS

Wrapped Bale Clamp



Wrapped Bale Clamp - CLBW 800

Capacity	Greutate	Înălțime globală	Lungime totală	Lățime	Reference number
800 kg	227 kg	810 mm	1386 mm	1587 mm	52000813

Mandatory machine equipment: 

Wrapped Bale Clamp - CLBW 1500

Capacity	Greutate	Înălțime globală	Lungime totală	Lățime	Reference number
1500 kg	251 kg	810 mm	1490 mm	1587 mm	52001012

Mandatory machine equipment: 

ON FORK HANDLING SOLUTIONS

Carriage Floating Load Backrest And Forks (MT - MLT)



Carriage Floating Load Backrest And Forks (MT - MLT) - CAF 1000 / 4.1 LB

Distance to center of gravity	Capacity	Greutate	Înălțime globală	Lungime totală	Lățime
275 mm	4100 kg	306 kg	1036 mm	1514 mm	1160 mm

Reference number
52722290

Mandatory machine equipment: ✕

ON FORK HANDLING SOLUTIONS

Floating Forks Carriage (MLT - MT)



Floating Forks Carriage (MLT - MT) - TFF 45 MT (a)

Capacity	Lățime
4500 kg	1160 mm

Mandatory machine equipment: ✕



Floating Forks Carriage (MLT - MT) - TFF 45 MT (c)

Capacity	Lățime
4500 kg	1420 mm

Mandatory machine equipment: ✕

ON FORK HANDLING SOLUTIONS

Tilting Forks Carriage



Tilting Forks Carriage - PFB 45N 1670

Capacity	Greutate	Lățime	Reference number
4500 kg	252 kg	1696 mm	653747

Mandatory machine equipment: ✕



Tilting Forks Carriage - PFB 45N 2000

Capacity	Greutate	Lățime	Reference number
4500 kg	295 kg	2026 mm	653748

Mandatory machine equipment: ✕

ON FORK HANDLING SOLUTIONS

Tilting Forks Carriage With Load Backrest (MLT - MT)



Tilting Forks Carriage With Load Backrest (MLT - MT) - PFB 45N 1670 LB

Capacity	Greutate	Înălțime globală	Lățime
4500 kg	310 kg	1209 mm	1810 mm

Mandatory machine equipment: ✕



Tilting Forks Carriage With Load Backrest (MLT - MT) - PFB 45N 2000 LB

Capacity	Greutate	Înălțime globală	Lățime
4500 kg	360 kg	1209 mm	2140 mm

Mandatory machine equipment: ✕

FORKS & GRABS

High Capacity Silage & Manure Grab



High Capacity Silage & Manure Grab - FMG 2450 / 2000

Capacity	Heaped capacity	Greutate	Lungime totală	Forks length	Lățime
1400 kg	2000 l	686 kg	1381 mm	990 mm	2435 mm
Closed grab height	Reference number				
1201 mm	790534				

Mandatory machine equipment: 📏

FORKS & GRABS

Manure Fork With Grapple



Manure Fork With Grapple - FFGR 2100

Capacity	Heaped capacity	Greutate	Lungime totală	Forks length	Fork spread
1700 kg	1100 l	492 kg	1322 mm	810 mm	225 mm
Lățime	Closed grab height	Opened grab height	Reference number		
2100 mm	1138 mm	1636 mm	751403		

Mandatory machine equipment: 

Manure Fork With Grapple - FFGR 2400

Capacity	Heaped capacity	Greutate	Lungime totală	Forks length	Fork spread
1700 kg	1300 l	528 kg	1325 mm	810 mm	225 mm
Lățime	Closed grab height	Opened grab height	Reference number		
2400 mm	1138 mm	1615 mm	751405		

Mandatory machine equipment: 

FORKS & GRABS

Shear Grab



Shear Grab - SHG 2400 / 1800

Capacity	Heaped capacity	Greutate	Lungime totală	Lățime	Closed grab height
1579 kg	1754 l	936 kg	1295 mm	2454 mm	1010 mm
Opened grab height	Depth	Reference number			
1475 mm	850 mm	52000383			

Mandatory machine equipment: 

FORKS & GRABS

Square Bale Forks



Square Bale Forks - FB 1900 / 1700

Capacity	Greutate	Înălțime globală	Lungime totală	Forks length	Fork spread
1700 kg	215 kg	2236 mm	1341 mm	1010 mm	600 mm
Lățime	Reference number				
1878 mm	790699				

Mandatory machine equipment: 

BRAȚE

Big Bag Handler



Big Bag Handler - HBB 1500 / 2400

Distance to center of gravity	Capacity	Greutate	Înălțime globală	Lungime totală	Fork spread
388 mm	2400 kg	186 kg	1322 mm	1643 mm	750 mm
Lățime	Reference number	Reference number E-RECO	Skid Steer Carriage reference	4 point Carriage	Euro Carriage
1356 mm	52781808	931627	52578030	52742058	52742059

Mandatory machine equipment: ✕

SWEEPER & CLEANER

Sweeper 2 in 1



Sweeper 2 in 1 - SCC 2600

Heaped capacity	Greutate	Înălțime globală	Lungime totală	Lățime	Reference number
250 l	755 kg	950 mm	2140 mm	2820 mm	52000515

Mandatory machine equipment:



Sweeper 2 in 1 - SCC 2600 +

Heaped capacity	Greutate	Înălțime globală	Lungime totală	Lățime	Reference number
250 l	730 kg	950 mm	2170 mm	2820 mm	52000517
Reference number E-RECO					
52000517					

Mandatory machine equipment:

MISCELLANEOUS ATTACHMENTS

Material Basket



Material Basket - MB 2000 / 1000

Distance to center of gravity	Capacity	Greutate	Înălțime globală	Lungime totală	Lățime
694 mm	1000 kg	400 kg	1215 mm	1632 mm	2056 mm
Depth	Reference number				
1120 mm	52596600				

Mandatory machine equipment: ✕

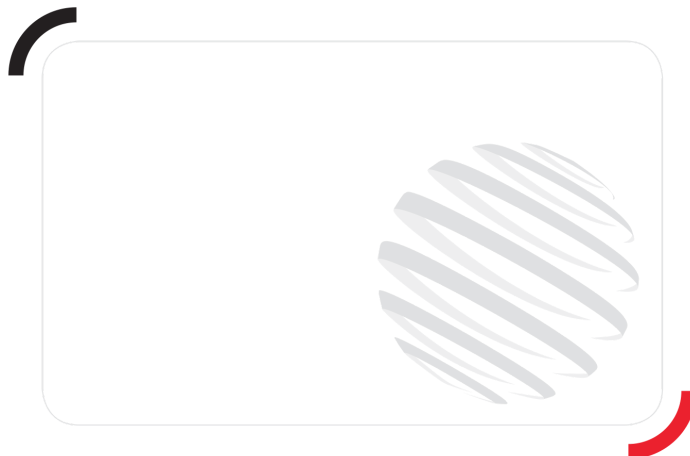

Head Office

B.P. 249 - 430 rue de l'Aubinière
44150 Ancenis Cedex - France

Tel: +33 (0)2 40 09 10 11 - Fax: +33 (0)2 40 09 10 97

www.manitou.com



În această broșură sunt descrise versiunile și opțiunile de configurare pentru produsele Manitou care pot fi prevăzute cu diferite echipamente. Echipamentele descrise în această broșură pot fi standard, opționale sau indisponibile, în funcție de versiune. Manitou își rezervă dreptul de a modifica specificațiile indicate și descrise în orice moment și fără avertizare prealabilă. Producătorul nu este responsabil pentru specificațiile furnizate. Pentru mai multe informații, contactați distribuitorul Manitou. Document necontractual. Este posibil ca descrierile produselor să difere de cele ale produselor reale. Siglele și identitatea vizuală ale companiei sunt proprietatea Manitou și nu pot fi utilizate fără autorizație. Toate drepturile rezervate. Fotografiiile și diagramele incluse în această broșură sunt furnizate numai cu caracter informativ.

MANITOU BF SA - Companie cu răspundere limitată cu comitet director - Capital acțiuni: 39.668.399 euro - 857 802 508 RCS Nantes