

Română

Agricultural telehandlers

MLT NewAg

MLT 630-115

MACHINEBOOK



Capacities		Metric
Capacitate maximă	Q	3000 kg
Înălțime max. de ridicare	h3	6.10 m
Rază de acțiune maximă		3.34 m
Rată de acțiune la înălțime maximă		0.90 m
Forță de susținere verticală cu cupă		4517 daN
Greutate și dimensiuni		
Unladen weight (with forks)		7010 kg
Gardă la sol utilaj	m4	0.35 m
Ampatament	y	2.69 m
Lungime globală la cărucior (cu cuplaj)	l11	4.78 m
Lungime globală la cărucior (fără cuplaj)	l3	4.63 m
Consolă față		1.25 m
Lățime globală	b1	2.13 m
Lățime globală cabină	b4	0.95 m
Înălțime globală	h17	2.34 m
Unghi înclinare jos	a5	133 °
Unghi înclinare sus	a4	13 °
Rază de bracăj exterioară (peste anvelope)	Wa1	3.68 m
Standard tires		Alliance - A580 - 405/70 R24 152A8
Drive wheels (front / rear)		2 / 2
Steering wheels (front / rear)		2 / 2
Performances		
Lifting		6.50 s
Lowering		4.80 s
Extensie telescop		6 s
Retragere		5.20 s
Excavație		3.30 s
Descărcare		2.60 s
Engine		
Marcă		Deutz
Engine norm		Stage V
Tip		TCD 3.6 L4
Number of cylinders - Capacity of cylinders		4 - 3621 cm ³
I.C. Engine power rating / Power		116 Hp / 85 kW
Max. torque / Engine rotation		460 Nm @1600 rpm
Forță de tracțiune pe orizontală		6300 daN
Ventilator reversibil		Standard
Engine cooling system		5 (radiators water + intercooler + hydraulic oil + transmission oil + fuel)
HVO validated (according to EN 15940 standard)		Da
Transmission		
Transmission type		Torque converter
Gearbox		Powershuttle
Number of gears (forward / reverse)		4 / 4
Viteză maximă de deplasare (poate varia în funcție de reglementările în vigoare)		40 km/h
Differential lock		Limited slip differential on front axle
Frână de parcare		Manual
Service brake		Oil-immersed multi-discs braking on front & rear axles
Hydraulics		
Tip pompă		Gear pump
Debit hidraulic - Presiune hidraulică		106 l/min - 250 bar
Distribuitor cu partajare debit		Option
Tank capacities		
Capacitate rezervor de carburant		78 l
Diesel Exhaust fluid (AdBlue® type)		13 l
Noise and vibration		
Zgomot la poziția de conducere (LpA) testat conform noimei NF EN 12053		74 dB
Zgomot în mediu (LwA)		105 dB
Vibrație la brațe/mâini		< 2.50 m/s ²
Miscellaneous		
Tractor homologation		Tractor homologation
Safety cab homologation		ROPS - FOPS level 2 cab
Controale		JSM

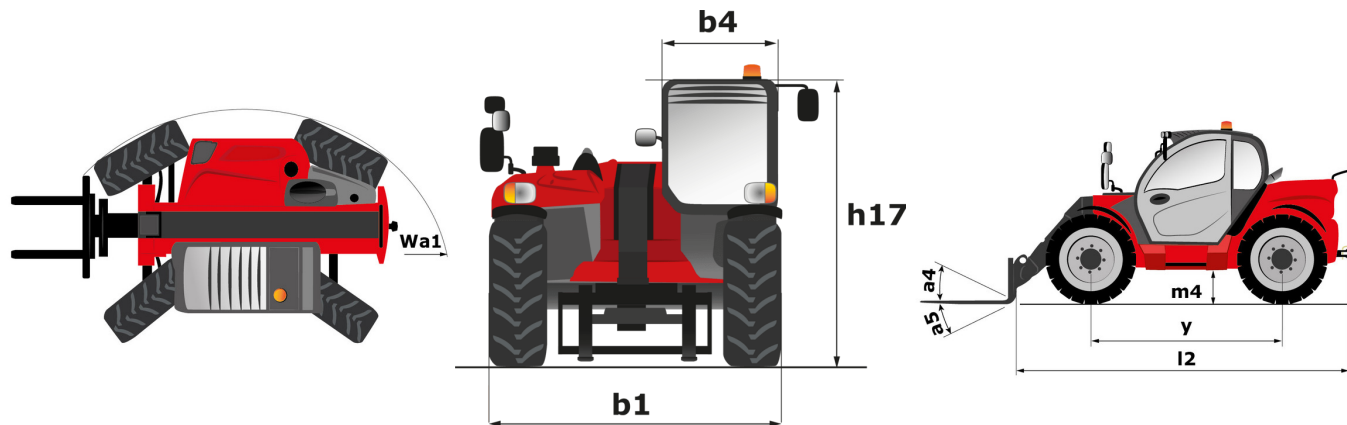

MLT 630-115 - DIAGRAMĂ DE ÎNCĂRCARE

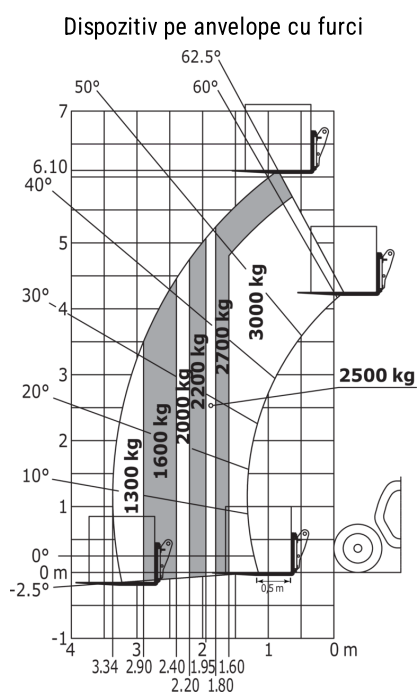

BUCKETS

Agricultural Bucket

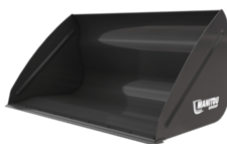

Agricultural Bucket - CBA 1500 / 2450

Distance to center of gravity	Capacity	Heaped capacity	Struck capacity	Greutate	Înălțime globală
542 mm	1529 kg	1529 l	1101 l	500 kg	997 mm
Lungime totală	Lățime	Reference number	Reference number with bolted wearplate (WP)		
1170 mm	2450 mm	570547	570548		

Mandatory machine equipment: ✕

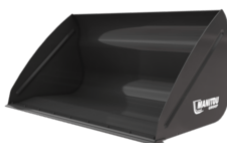

Agricultural Bucket - CBA 1700L / 2100

Distance to center of gravity	Capacity	Heaped capacity	Struck capacity	Greutate	Înălțime globală
440 mm	1703 kg	1703 l	1271 l	512 kg	1150 mm
Lungime totală	Lățime	Reference number	Reference number with bolted wearplate (WP)		
1190 mm	2100 mm	570549	52610570		

Mandatory machine equipment: ✕

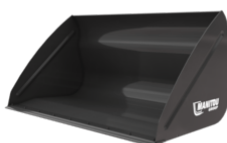

Agricultural Bucket - CBA 2000 / 2450

Distance to center of gravity	Capacity	Heaped capacity	Struck capacity	Greutate	Înălțime globală
485 mm	2010 kg	2010 l	1484 l	557 kg	1150 mm
Lungime totală	Lățime	Reference number	Reference number with bolted wearplate (WP)		
1204 mm	2450 mm	570551	570552		

Mandatory machine equipment: ✕

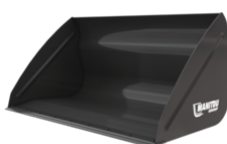

Agricultural Bucket - CBA 2000L / 2250

Distance to center of gravity	Capacity	Heaped capacity	Struck capacity	Greutate	Înălțime globală
664 mm	1970 kg	1970 l	1456 l	585 kg	1104 mm
Lungime totală	Lățime	Reference number	Reference number with bolted wearplate (WP)		
1422 mm	2250 mm	790540	790541		

Mandatory machine equipment: ✕

BUCKETS

Agricultural Multifunction Grab Bucket - FO



Agricultural Multifunction Grab Bucket - FO - BG 2100 / 1200 FO

Distance to center of gravity	Capacity	Heaped capacity	Struck capacity	Greutate	Lungime totală
396 mm	1200 kg	1200 l	740 l	720 kg	1256 mm
Lăţime	Closed grab height	Opened grab height	Reference number		
2100 mm	1033 mm	1675 mm	52647329		

Mandatory machine equipment: 



Agricultural Multifunction Grab Bucket - FO - BG 2300 / 1350 FO

Distance to center of gravity	Capacity	Heaped capacity	Struck capacity	Greutate	Lungime totală
408 mm	1335 kg	1335 l	813 l	763 kg	1256 mm
Lăţime	Closed grab height	Opened grab height	Reference number		
2300 mm	1031 mm	1675 mm	52647331		

Mandatory machine equipment: 



Agricultural Multifunction Grab Bucket - FO - BG 2450 / 1400 FO

Distance to center of gravity	Capacity	Heaped capacity	Struck capacity	Greutate	Lungime totală
407 mm	1426 kg	1426 l	868 l	803 kg	1256 mm
Lăţime	Closed grab height	Opened grab height	Reference number		
2450 mm	1033 mm	1675 mm	52647333		

Mandatory machine equipment: 



Agricultural Multifunction Grab Bucket - FO - BG 2450 / 1700 FO

Capacity	Heaped capacity	Struck capacity	Greutate	Lungime totală	Lăţime
1695 kg	1695 l	1150 l	870 kg	1367 mm	2450 mm
Closed grab height	Opened grab height	Reference number			
1124 mm	1886 mm	52549810			

Mandatory machine equipment: 

BUCKETS

Agricultural Multifunction Grab Bucket - WE



Agricultural Multifunction Grab Bucket - WE - BG 2100 / 1200 WE

Distance to center of gravity	Capacity	Heaped capacity	Struck capacity	Greutate	Lungime totală
412 mm	1200 kg	1200 l	740 l	745 kg	1280 mm
Lăţime	Closed grab height	Opened grab height	Reference number		
2100 mm	1032 mm	1776 mm	52647328		

Mandatory machine equipment: 



Agricultural Multifunction Grab Bucket - WE - BG 2300 / 1350 WE

Distance to center of gravity	Capacity	Heaped capacity	Struck capacity	Greutate	Lungime totală
413 mm	1335 kg	1335 l	813 l	785 kg	1280 mm
Lăţime	Closed grab height	Opened grab height	Reference number		
2300 mm	1031 mm	1776 mm	52647330		

Mandatory machine equipment: 



Agricultural Multifunction Grab Bucket - WE - BG 2450 / 1400 WE

Distance to center of gravity	Capacity	Heaped capacity	Struck capacity	Greutate	Lungime totală
418 mm	1426 kg	1426 l	868 l	813 kg	1280 mm
Lăţime	Closed grab height	Opened grab height	Reference number		
2450 mm	1033 mm	1776 mm	52647332		

Mandatory machine equipment: 

BUCKETS

Construction Bucket



Construction Bucket - CBC 750L / 2100

Distance to center of gravity	Capacity	Heaped capacity	Struck capacity	Greutate	Înălţime globală
360 mm	1613 kg	768 l	616 l	345 kg	810 mm
Lungime totală	Lăţime	Reference number			
1048 mm	2100 mm	654475			

Mandatory machine equipment: 



Construction Bucket - CBC 800L / 2250

Distance to center of gravity	Capacity	Heaped capacity	Struck capacity	Greutate	Înălțime globală
355 mm	1709 kg	814 l	666 l	366 kg	810 mm
Lungime totală	Lățime	Reference number	Reference number TSDL		
1026 mm	2250 mm	654471	52000363		

Mandatory machine equipment: ✕

BUCKETS

General Purpose Bucket



General Purpose Bucket - CBR 850 / 2100

Capacity	Heaped capacity	Struck capacity	Greutate	Înălțime globală	Lungime totală
1770 kg	843 l	685 l	358 kg	775 mm	838 mm
Lățime	Reference number				
2100 mm	653047				

Mandatory machine equipment: ✕



General Purpose Bucket - CBR 900 / 2250

Capacity	Heaped capacity	Struck capacity	Greutate	Înălțime globală	Lungime totală
1898 kg	904 l	736 l	360 kg	775 mm	815 mm
Lățime	Reference number	Reference number TSDL	Reference number E-RECO		
2250 mm	653749	52000365	921281		

Mandatory machine equipment: ✕

BUCKETS

General Purpose Bucket Essential



General Purpose Bucket Essential - BGP 2000 / 800 Essential

Distance to center of gravity	Capacity	Heaped capacity	Struck capacity	Greutate	Înălțime globală
425 mm	1684 kg	802 l	622 l	345 kg	786 mm
Lungime totală	Lățime	Depth	Reference number		
925 mm	2000 mm	817 mm	52688160		

Mandatory machine equipment: ✕

BUCKETS

Silage Facing Bucket



Silage Facing Bucket - CRS 2350 / 1800

Capacity	Heaped capacity	Greutate	Lățime	Reference number
1800 kg	1800 l	900 kg	2350 mm	52612542

Mandatory machine equipment:  + 

BUCKETS

Sugar Beet Bucket

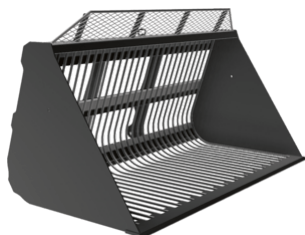

Sugar Beet Bucket - BSB 2450 / 2500

Distance to center of gravity	Capacity	Heaped capacity	Greutate	Înălțime globală	Lungime totală
502 mm	1390 kg	2500 l	520 kg	1380 mm	1375 mm
Lățime	Depth	Reference number			
2450 mm	1280 mm	757953			

Mandatory machine equipment: 

CLAMPS

Bale clamp classic



Bale clamp classic - CLBR 2x3

Capacity	Greutate	Înălțime globală	Lungime totală	Forks length	Lățime
1200 kg	235 kg	1382 mm	1082 mm	335 mm	1090 mm
Arm length	Reference number				
700 mm	52001013				

Mandatory machine equipment:  



Bale clamp classic - PBG 2x4

Capacity	Greutate	Înălțime globală	Lungime totală	Forks length	Lățime
1800 kg	235 kg	1381 mm	1031 mm	335 mm	1090 mm
Arm length	Reference number				
600 mm	757612				

Mandatory machine equipment:  

CLAMPS

Bale Clamp Intensive**Bale Clamp Intensive - Lower Tines**

Greutate	Lungime totală	Diameter	Reference number
35 kg	680 mm	35 mm	790521

**Bale Clamp Intensive - P2BG 2x4**

Capacity	Greutate	Înălțime globală	Lungime totală	Lățime	Arm length
1800 kg	283 kg	1776 mm	1047 mm	1090 mm	600 mm

Reference number
790518

Mandatory machine equipment: 

CLAMPS

Bale Clamp Super Compact**Bale Clamp Super Compact - PBG 2x2**

Capacity	Greutate	Înălțime globală	Lungime totală	Forks length	Lățime
800 kg	156 kg	869 mm	922 mm	335 mm	1090 mm

Arm length	Reference number
500 mm	757639

Mandatory machine equipment: 

CLAMPS

Mixed Bale Clamp**Mixed Bale Clamp - MBC 2x3**

Capacity	Greutate	Înălțime globală	Lungime totală	Fork spread	Lățime
800 kg	290 kg	1084 mm	1454 mm	375 mm	1196 mm

Reference number
790506

Mandatory machine equipment: 

CLAMPS

Square wrapped bale clamp



Square wrapped bale clamp - CLBSW 2000 / 1000

Capacity	Greutate	Înălțime globală	Lungime totală	Lățime	Arm length
1000 kg	483 kg	679 mm	1849 mm	1525 mm	1000 mm

Reference number
52000812

Mandatory machine equipment:

CLAMPS

Wrapped Bale Clamp



Wrapped Bale Clamp - CLBW 800

Capacity	Greutate	Înălțime globală	Lungime totală	Lățime	Reference number
800 kg	227 kg	810 mm	1386 mm	1587 mm	52000813

Mandatory machine equipment:



Wrapped Bale Clamp - CLBW 1500

Capacity	Greutate	Înălțime globală	Lungime totală	Lățime	Reference number
1500 kg	251 kg	810 mm	1490 mm	1587 mm	52001012

Mandatory machine equipment:

ON FORK HANDLING SOLUTIONS

Floating Forks Carriage (MLT - MT)



Floating Forks Carriage (MLT - MT) - TFF 35 MT (a)

Capacity	Lățime
3500 kg	1140 mm

Mandatory machine equipment:



Floating Forks Carriage (MLT - MT) - TFF 35 MT (c)

Capacity	Lățime
3500 kg	1400 mm

Mandatory machine equipment: ✕

ON FORK HANDLING SOLUTIONS

Tilting Forks Carriage



Tilting Forks Carriage - PFB 35N 1470

Capacity	Greutate	Lățime	Reference number
3500 kg	117 kg	1512 mm	653745

Mandatory machine equipment: ✕



Tilting Forks Carriage - PFB 35N 1580

Capacity	Greutate	Lățime	Reference number
3500 kg	122 kg	1622 mm	653746

Mandatory machine equipment: ✕

ON FORK HANDLING SOLUTIONS

Tilting Forks Carriage With Load Backrest (MLT - MT)



Tilting Forks Carriage With Load Backrest (MLT - MT) - PFB 35N 1260 LB

Capacity	Greutate	Înălțime globală	Lățime
3500 kg	130 kg	1185 mm	1284 mm

Mandatory machine equipment: ✕



Tilting Forks Carriage With Load Backrest (MLT - MT) - PFB 35N 1470 LB

Capacity	Greutate	Înălțime globală	Lățime
3500 kg	158 kg	1185 mm	1494 mm

Mandatory machine equipment: ✕

FORKS & GRABS

High Capacity Silage & Manure Grab



High Capacity Silage & Manure Grab - FMG 2100 / 1800 ONLY UK IRL

Capacity	Heaped capacity	Greutate	Lungime totală	Forks length	Lățime
1260 kg	1800 l	510 kg	1352 mm	990 mm	2100 mm
Closed grab height	Reference number				
1223 mm	52000082				

Mandatory machine equipment: 🍴🍴

FORKS & GRABS

Manure Fork With Grapple



Manure Fork With Grapple - FFGR 1950

Capacity	Heaped capacity	Greutate	Lungime totală	Forks length	Fork spread
1580 kg	1000 l	477 kg	1322 mm	810 mm	225 mm
Lățime	Closed grab height	Opened grab height	Reference number		
1950 mm	1138 mm	1625 mm	751404		

Mandatory machine equipment: 🍴🍴



Manure Fork With Grapple - FFGR 2100

Capacity	Heaped capacity	Greutate	Lungime totală	Forks length	Fork spread
1700 kg	1100 l	492 kg	1322 mm	810 mm	225 mm
Lățime	Closed grab height	Opened grab height	Reference number		
2100 mm	1138 mm	1636 mm	751403		

Mandatory machine equipment: 🍴🍴

Manure Fork With Grapple - FFGR 2400

Capacity	Heaped capacity	Greutate	Lungime totală	Forks length	Fork spread
1700 kg	1300 l	528 kg	1325 mm	810 mm	225 mm
Lăţime	Closed grab height	Opened grab height	Reference number		
2400 mm	1138 mm	1615 mm	751405		

Mandatory machine equipment:

FORKS & GRABS

Shear Grab

Shear Grab - SHG 1800 / 1350

Capacity	Heaped capacity	Greutate	Lungime totală	Lăţime	Closed grab height
1184 kg	1315 l	749 kg	1295 mm	1854 mm	1010 mm
Opened grab height	Depth	Reference number			
1475 mm	850 mm	52000381			

Mandatory machine equipment:

FORKS & GRABS

Square Bale Forks

Square Bale Forks - FB 1900 / 1700

Capacity	Greutate	Înălţime globală	Lungime totală	Forks length	Fork spread
1700 kg	215 kg	2236 mm	1341 mm	1010 mm	600 mm
Lăţime	Reference number				
1878 mm	790699				

Mandatory machine equipment: ✕

BRAŢE

Big Bag Handler

Big Bag Handler - HBB 1500 / 2400

Distance to center of gravity	Capacity	Greutate	Înălţime globală	Lungime totală	Fork spread
388 mm	2400 kg	186 kg	1322 mm	1643 mm	750 mm
Lăţime	Reference number	Reference number E-RECO	Skid Steer Carriage reference	4 point Carriage	Euro Carriage
1356 mm	52781808	931627	52578030	52742058	52742059

Mandatory machine equipment: ✕

MISCELLANEOUS ATTACHMENTS

Material Basket**Material Basket - MB 2000 / 1000**

Distance to center of gravity	Capacity	Greutate	Înălțime globală	Lungime totală	Lățime
694 mm	1000 kg	400 kg	1215 mm	1632 mm	2056 mm
Depth	Reference number				
1120 mm	52596600				

Mandatory machine equipment: X

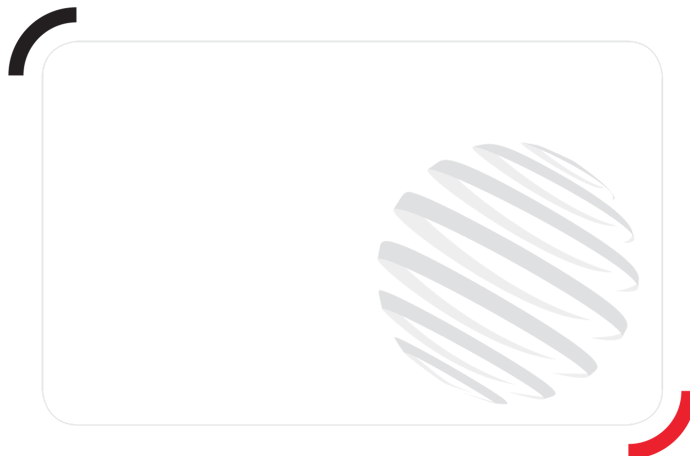

Head Office

B.P. 249 - 430 rue de l'Aubinière
44150 Ancenis Cedex - France

Tel: +33 (0)2 40 09 10 11 - Fax: +33 (0)2 40 09 10 97

www.manitou.com



În această broșură sunt descrise versiunile și opțiunile de configurare pentru produsele Manitou care pot fi prevăzute cu diferite echipamente. Echipamentele descrise în această broșură pot fi standard, opționale sau indisponibile, în funcție de versiune. Manitou își rezervă dreptul de a modifica specificațiile indicate și descrise în orice moment și fără avertizare prealabilă. Producătorul nu este responsabil pentru specificațiile furnizate. Pentru mai multe informații, contactați distribuitorul Manitou. Document necontractual. Este posibil ca descrierile produselor să difere de cele ale produselor reale. Siglele și identitatea vizuală ale companiei sunt proprietatea Manitou și nu pot fi utilizate fără autorizație. Toate drepturile rezervate. Fotografiiile și diagramele incluse în această broșură sunt furnizate numai cu caracter informativ.

MANITOU BF SA - Companie cu răspundere limitată cu comitet director - Capital acțiuni: 39.668.399 euro - 857 802 508 RCS Nantes